

## NDA S-SIGHT

Provision-ISR S-SIGHT series provides you with all you need for a simple installation. S-Sight cameras guarantee superior image quality, improved night performance and make an outstanding value-for-money solution.



# I2-340IPSN-28-V2

## 20M IR 4MP FIXED LENS BULLET CAMERA

Equipped with a 2.8mm fixed lens, this 4MP bullet camera is designed for short-distance surveillance (up to 20m) in indoor and outdoor scenarios. The camera offers outstanding DDA Analytics (Detect, Distinguish, Alert), which can perform human and vehicle recognition. With its excellent performance, reliability, and affordable price, the I2-340IPSN-28-V2 camera is the perfect solution for any basic installation.



### MAIN FEATURES

- 4MP
- NDA S-SIGHT
- 2592×1520 Resolution
- Wide field of view 110°
- 3D-DNR
- IP67
- DDA Analytics

### ANALYTICS

- General Analytics: Camera Tampering
- AI (Object Recognition): DDA Sterile Area, DDA Line Crossing



## SPECIFICATIONS

Image Sensor	1/2.7" CMOS (16:9)
Effective Pixels	2560x1440
Electronic Shutter	1/25s ~ 1/100000s
Frame Rate	1-25/30FPS
Day & Night	ICR
Min. Illumination	Day: 0.1lux / Night: 0.04lux (@F2.2, AGC on) 0lux with IR on
Audio compression	N/A
Communication	N/A
Image Settings	AWB, AGC Adjustable, Exposure Mode (Auto) Sharpness, Saturation, Brightness & Contrast Adjustable
Image Enhancement	True WDR (120dB), BLC, HLC, ROI
Noise Reduction	3D-DNR
Image Orientation	Mirror/Flip
Privacy Zone	Yes
Motion Detection	Yes
Analytics	General Analytics: Camera Tampering AI (Object Recognition): DDA Sterile Area, DDA Line Crossing
DRI Distance	Detect 61.76m(202.62ft) Recognize 12.35m(40.51ft) Identify 6.18m(20.27ft)
Video Compression	H.265 / H.264 / MJPEG (Substream only)
Resolution	4MP (2560x1440) / 3MP (2304x1296) / 2MP (1920x1080) / D1 / QVGA /CIF
Multi-Stream	Master Stream: 4MP (2560x1440) / 3MP (2304x1296) / 2MP (1~30fps) Substream: 1MP (1~12/15fps) / QVGA/D1/CIF (1~30fps) Third Stream: QVGA/D1/CIF (1~30fps)
Bit rate	64Kbps ~ 5Mbps@H.265 / 64Kbps ~ 5Mbps@H.264
Encode Mode	VBR/CBR
Image Quality	Five levels under VBR; Free adjustment under CBR
IR Distance	20m (1 High-Power IR LED)
Lens (Field of View)	2.8mm (110°)

## SPECIFICATIONS

Iris	Fixed Iris
Lens Mount	M12 mount
Protection Rate	Water Proof: IP67
Bracket	3-Axis Bracket
Dimensions	172.2x73.4x74.5mm
Weight (gross)	~390g
Network	RJ45 (+PoE)
Power	DC Socket
Analog Video Output	No
Audio Connectivity	No
SD Card	Event/Schedule based Main/Substream recording (Up to 128Gb)
Hard Reset Button	Yes
Alarm	No
Remote Monitoring	IE Browsing, VMS Software, Provision Cam2 Mobile App
User Access	Supports simultaneous monitoring of up to 4 users with multi-stream real-time transmission
Network Protocol	IPv4, IPv6, TCP, UDP, DHCP, NTP, DDNS, 802.1X, RTSP, Multicast, UPnP, Email, FTP, HTTPS, QoS
ONVIF	Yes
Ethernet	100Mbps
PoE	Yes
Power Supply	DC12V/~420mA / PoE/~5.4W
Work Environment	-30°C~60°C, 10%~90% Humidity
Junction Box	PR-JB12IP66 - PR-JB12IP64

## DIMENSIONS

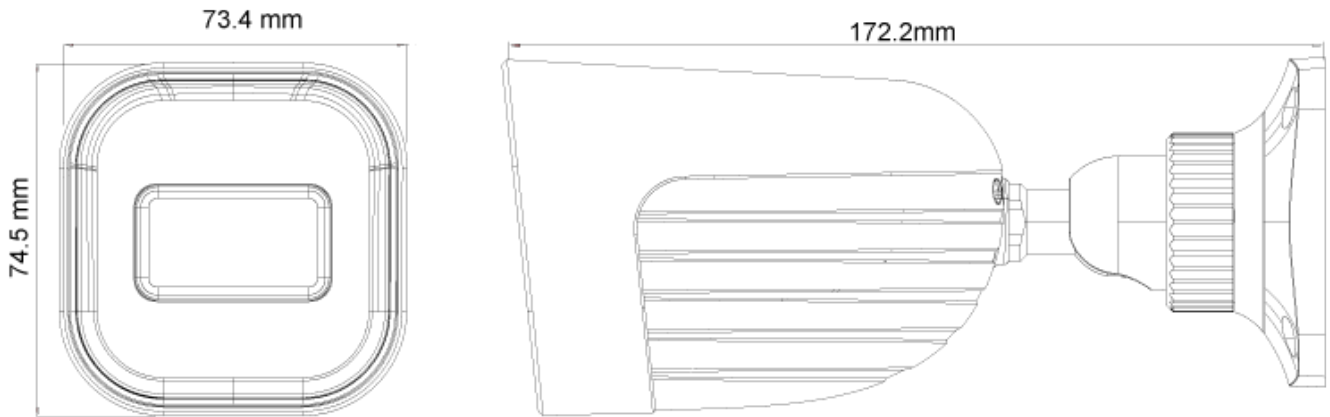

## ACCESSORIES

For I2-Fixed Lens & BSV-Fixed Lens

